

PYDAQ E800: Multichannel Wireless Programmable RTU

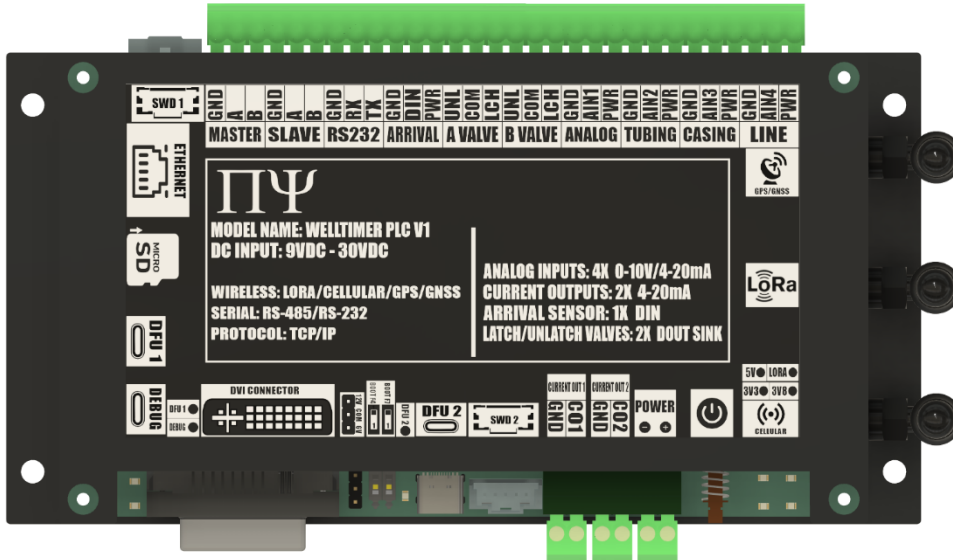

Features

I/O Analog/Digital Ports

- 8x Analog Inputs
- 8x Digital Inputs Dry Contact
- 8x Voltage Outputs
- 8x Current Outputs

Wired Com Ports

- RS-232 Modbus RTU
- Dual RS-485 Modbus RTU
- Ethernet Modbus TCP

Wireless Communication

- Radio ISM 900MHz RTU
- Cellular LTE 4G MQTT/HTTP

BLE Mobile Applications

- iOS Mobile App using BLE
- Android Mobile App using BLE

Overview

PYDAQ E800 is a 8-channel Analog Input, 8-channel Digital Input (Dry Contact), 8-channel Voltage Output and 8-Current Outputs Wireless RTU. The Device is designed to interface to any 4-20mA and 0-10V sensors interface and Actuator Interface. This versatile device allows for efficient data acquisition and control, providing compatibility with a wide range of sensor and actuator interfaces. Raw data collected from the sensors can be processed by PytroAI Edge Computing Engine embedded into the device. Processed data can be accessed via several wired communication options using RS-232 and RS-485 Modbus RTU and using Modbus TCP over Ethernet.

Specifications

Power	Power Supply Voltage	9-30V
	Power Type	DC-in
	Current Draw	150mA@Typical 3A@Peak
Mechanical	Dimensions	152.05" L x 87.2" W x 1.6" H
	Enclosure	ABS Plastic
	IP Rating	IP 64
Environment	Operating Temperature	-40°C to 85°C
	Operating Humidity	5%~95% Relative Humidity, non-condensing
I/O Ports	Analog Inputs	8x Channel: 0-10V, 4-20mA
	Voltage Outputs	8x Channel: 0-10V Voltage Output
	Current Outputs	8x Channel: 4-20mA Current Outputs
	Digital Inputs	8x Channel: Dry Contact Digital Inputs
Wired Communication	RS-232	1x Port: Modbus RTU Master/Slave
	RS-485	1x Port: Modbus RTU Master/Slave
	Ethernet	1x Port: Modbus TCP Master/Slave
Wireless Communication	Radio	900MHz ISM Protocol: Star Topology
	Cellular	LTE 4G Protocol: MQTT/HTTPS
	Bluetooth	2.4GHz ISM Protocol: BLE
Certification	FCC, IC	

Pinout Diagram

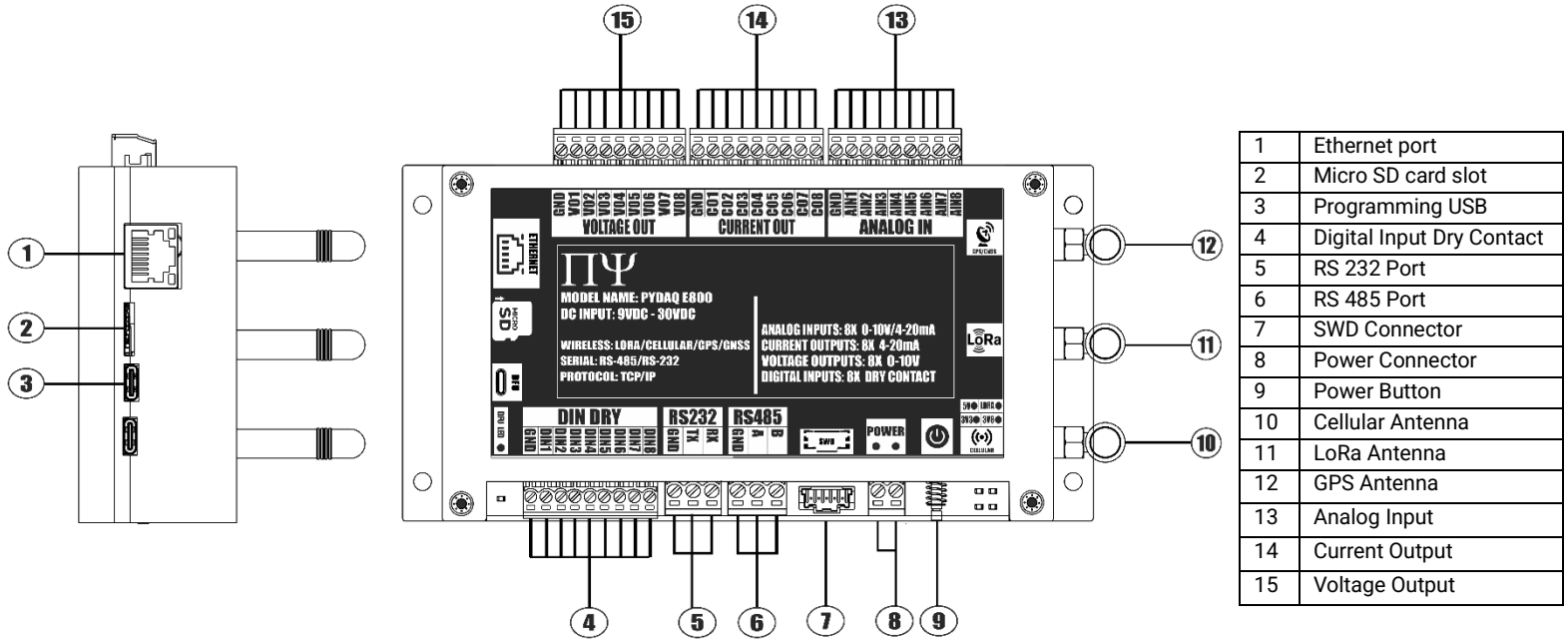

Mechanical Diagram

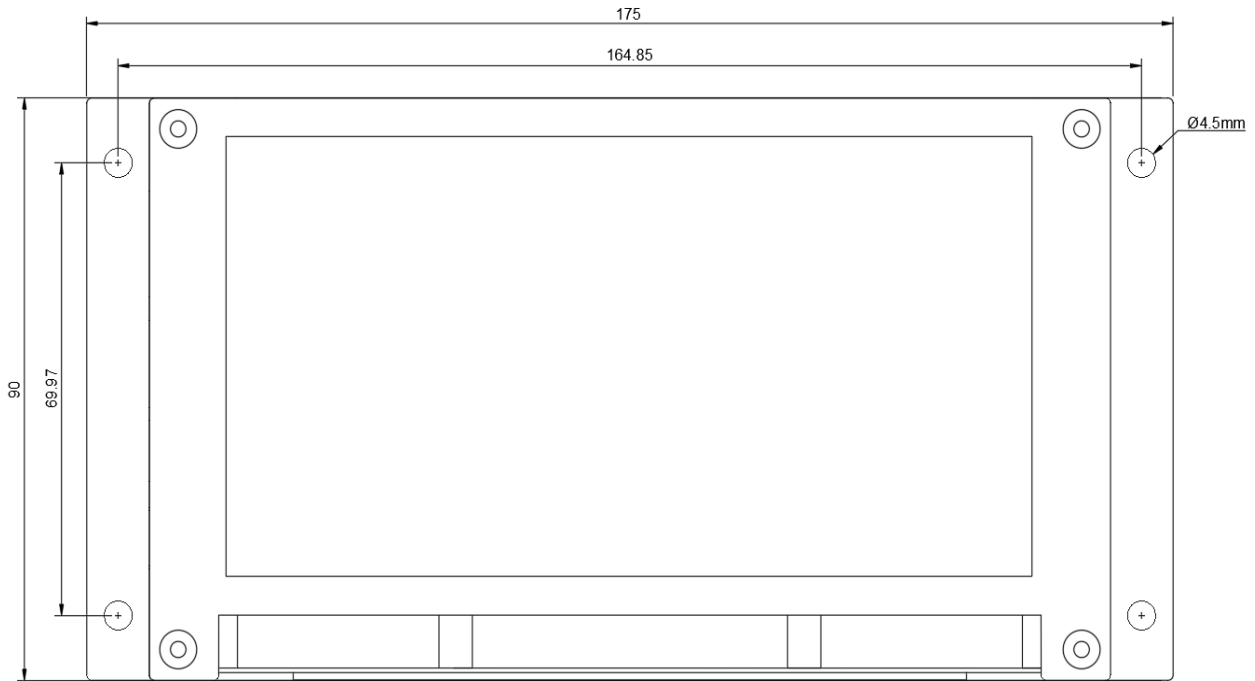

Wiring Diagram

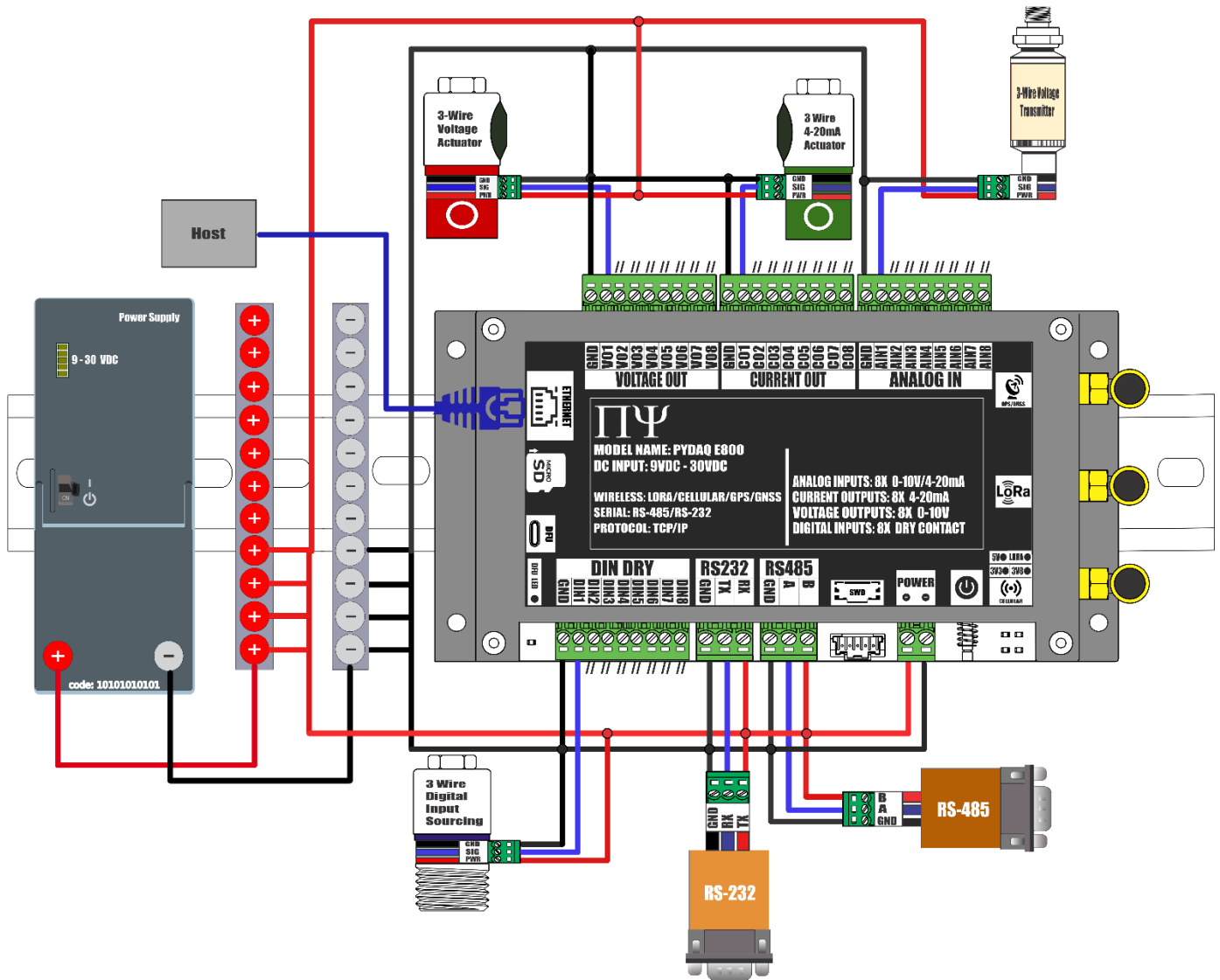

Software and Documentation	
Document	Software Configuration
Pydaq E800 Operation Manual	Pydaq E800 is configured using a browser based AI assisted tool called PytroAI. PytroAI is accessed by going to https://build.s2c.io/?username=demo The various application notes provide a detailed walkthrough for configuring the PYDAQ E800.
Pydaq E800 Software Manual	
Pydaq E800 Point-2-Point Radio Bridge Application Note	
Pydaq E800 Point-2-MultiPoint Radio Bridge Application Note	
Pydaq E800 Tank Level Monitoring Application Note	
Pydaq E800 Modbus RTU Master Application Note	
Pydaq E800 Modbus RTU Slave Application Note	
Pydaq E800 Modbus TCP Master Application Note	
Pydaq E800 Modbus TCP Slave Application Note	

Address: 1000 Innovation Dr. Suite 500, Kanata, Ont. K2K 3E7

Tel: 1-613-271-3729

Email: info@pytronix.com